

LEWA process diaphragm pumps

LEWA triplex[®] and LEWA ecoflow[®]
for process engineering.

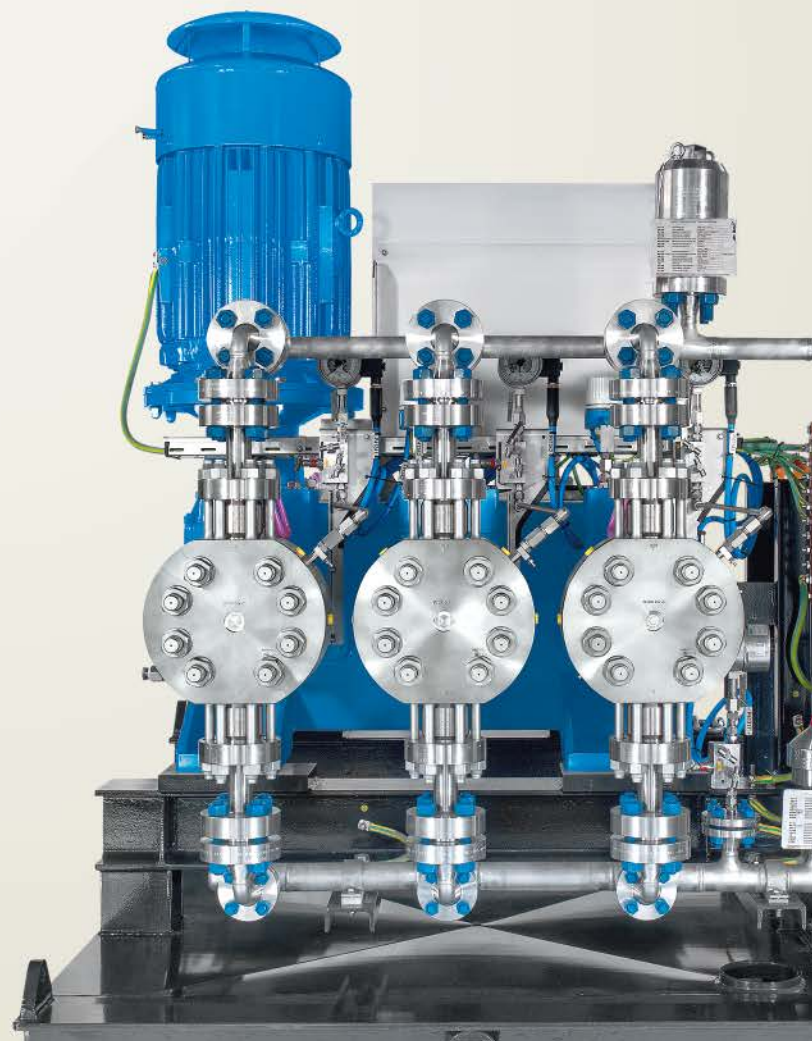



Industry: Oil & Gas

Installation location: Saudi Arabia

Application: MEG injection, flow rate of 4.5 m³/h at a pressure of 535 bar (API10000 design)

LEWA solution:

- Quintuplex process diaphragm pump in modular design
- Space-saving M800-PTFE pump heads
- Pump heads and piping made of super duplex SS material (API10000)





LEWA triplex and LEWA ecoflow process diaphragm pumps set the standard for process engineering, allowing even critical, toxic, or flammable fluids to be conveyed safely.

These pumps are also able to handle extremely low-viscosity, non-lubricating fluids, and abrasive suspensions without any problems, and feature a pressure range up to 1200 bar. LEWA's ongoing development of diaphragm pump technology ensures that it keeps on setting benchmarks.

Reliable components are one of the keys to safe processes. LEWA process diaphragm pumps are based on the robust technology that LEWA is renowned for. As a result, they are also easily able to fulfill the strict safety requirements of API 675 (American Petroleum Institute). The pumps use key components from LEWA's proven range – like the PTFE sandwich diaphragm with diaphragm monitoring, the patented DPS diaphragm protection system and flow efficient check valves.

- LEWA triplex is the world's most compact process diaphragm pump in any branch of industry. Its space and weight saving monoblock design also makes it suitable for any application with very little installation space.
- LEWA ecoflow is the most advanced process diaphragm pump in the world, offering maximum safety for production and the environment. The perfect solution for your application requirements can be configured from a wide variety of standardized assemblies. LEWA combines various pump heads and drive units with a variable modular construction, in line and boxer designs.

Industry: Refineries

Installation location: Germany

Application: Conveying methanol,
flow rate of 9.5 m³/h at a pressure of 44 bar

LEWA solution:

- Hermetically tight process diaphragm pump for conveying poisonous, highly flammable fluids
- Compact design
- Designed for continuous operation



LEWA process diaphragm pumps.

The advantages at a glance.

1

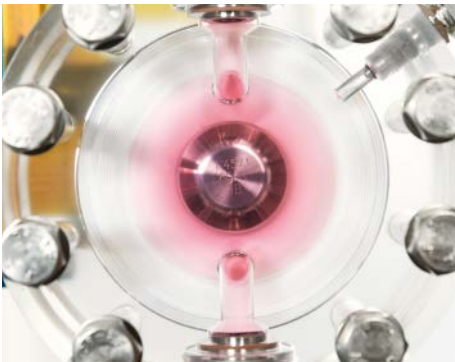

Hermetically tight

Diaphragm pumps work without dynamic seals, due to their design. This permits a hermetically tight working area. There are no external emissions and contamination of the fluid is impossible.

2



Maximum operational safety

Secure against misuse and against impermissible operating states, resulting in outstanding system availability. A monitoring system indicates possible diaphragm damage immediately. The pump can still be operated for a limited time.

3



Compact design

Thanks to the extremely space-saving and weight-saving monoblock design of the LEWA triplex, these process pumps are also ideal for applications with very little installation space.

4



Custom-made solutions

The modular system permits a wide variety of solution options – from the flexible modular construction, to the space-saving monoblock design, all the way through to special solutions. LEWA specializes in demanding applications.

5



Lowest life cycle costs

LEWA develops pumps for long service life. The assemblies run for decades in continuous operation. Our pumps achieve the highest efficiency of any pump technology.

6

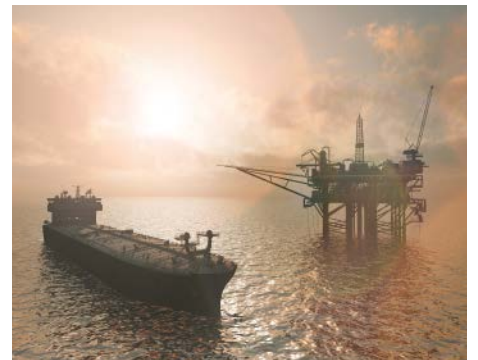

Worldwide service

LEWA is globally organized. Spare parts and service are quickly available worldwide.

References from customized process diaphragm pumps.

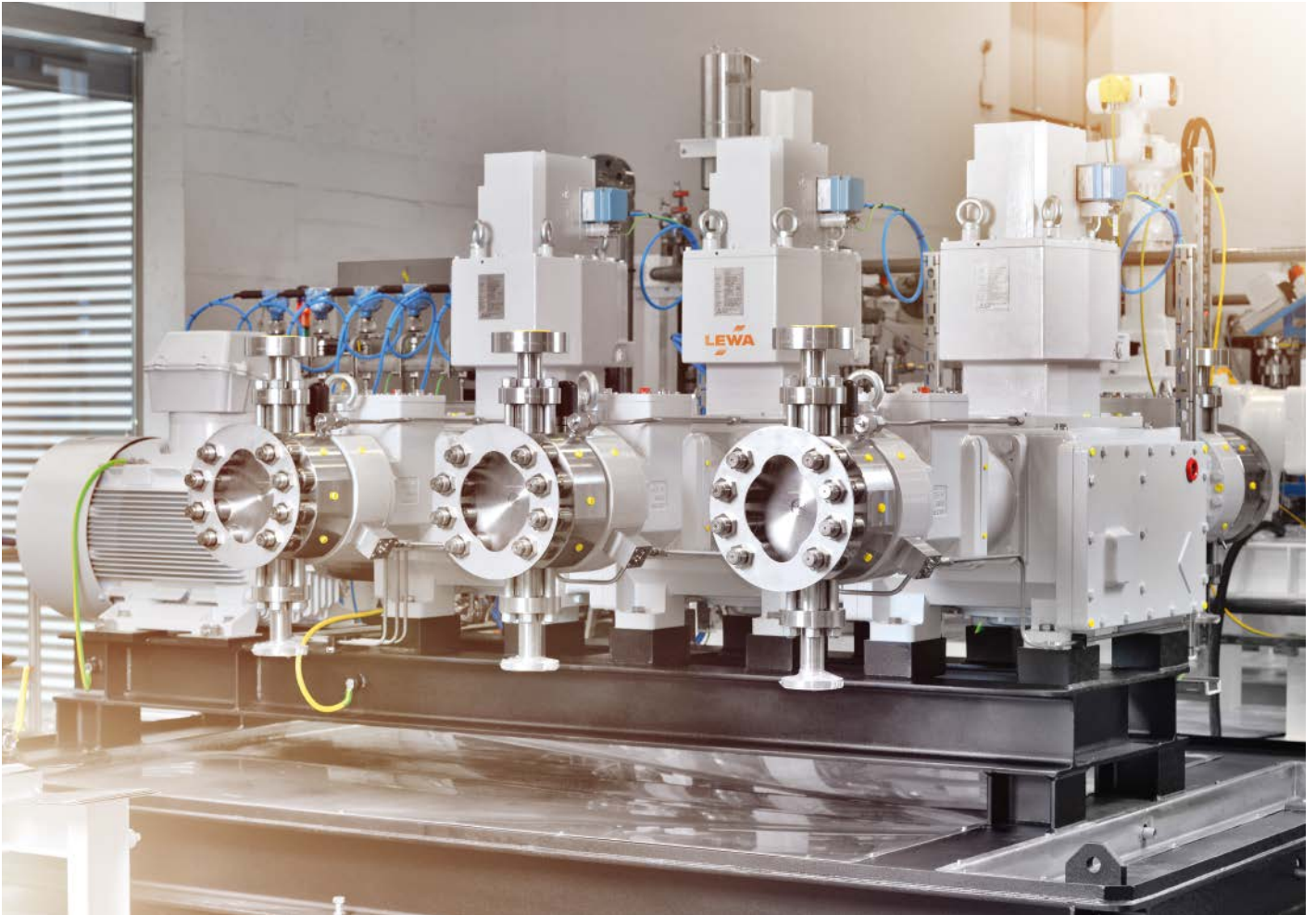

Industry: Chemicals

Installation location: China

Application: Conveying vinyl acetate,
flow rate of 9 m³/h at a pressure of 310 bar

LEWA solution:

- LEWA process diaphragm pump
in boxer design
- Hermetically tight diaphragm pump heads
- Extremely wide control range



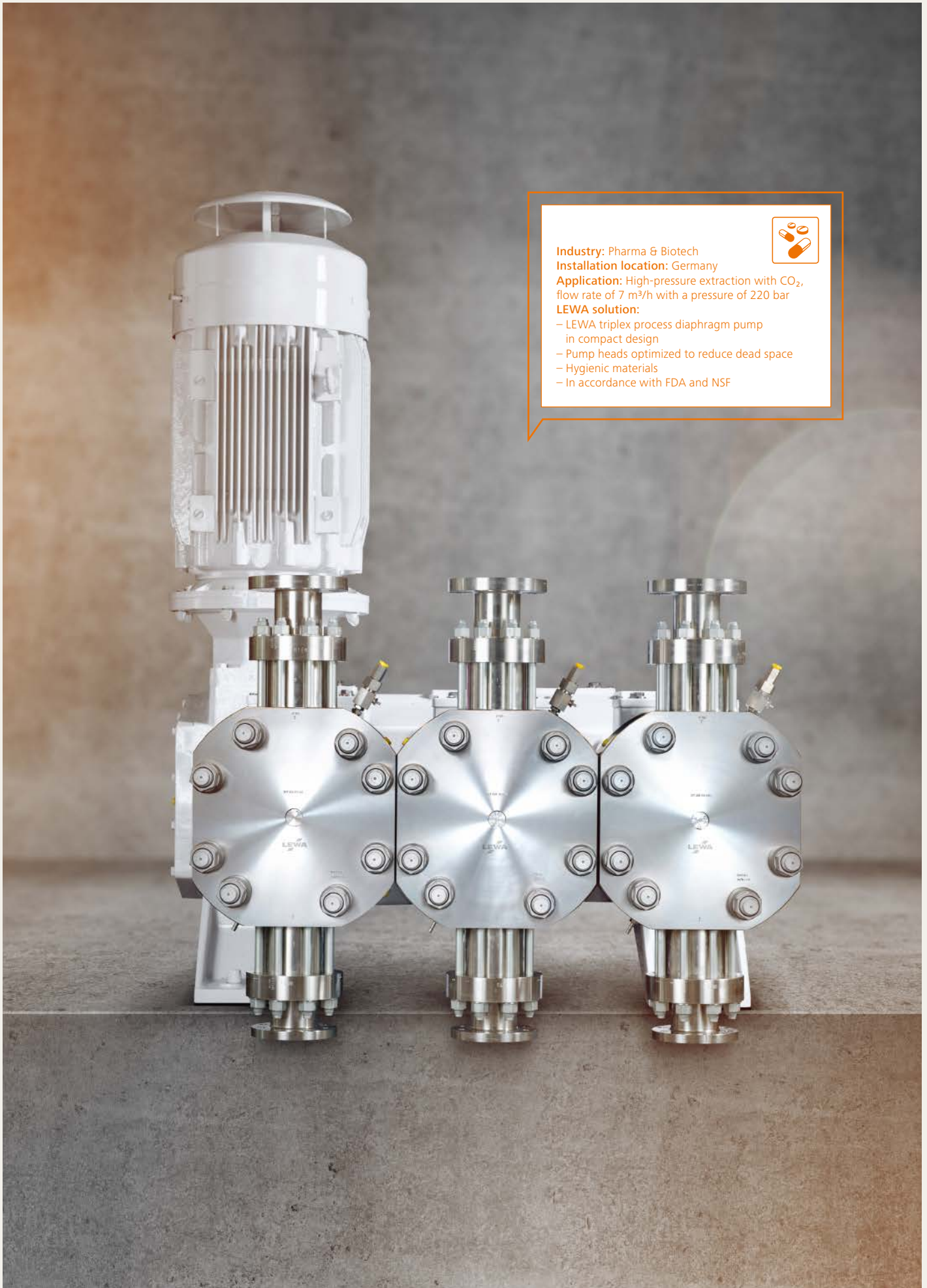

Industry: Pharma & Biotech

Installation location: Germany

Application: High-pressure extraction with CO₂,
flow rate of 7 m³/h with a pressure of 220 bar

LEWA solution:

- LEWA triplex process diaphragm pump
in compact design
- Pump heads optimized to reduce dead space
- Hygienic materials
- In accordance with FDA and NSF

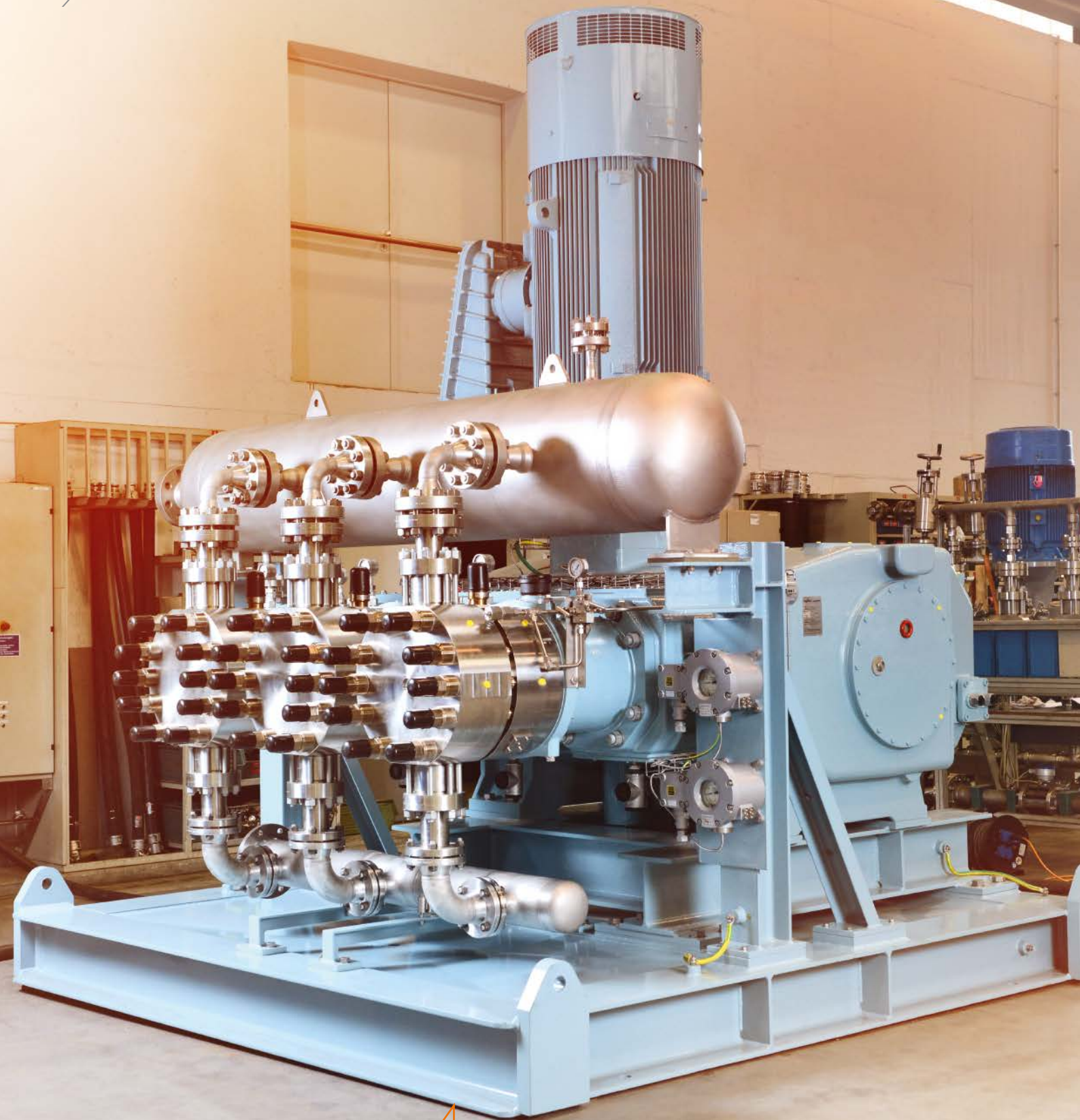

Industry: Chemicals

Installation location: Japan

Application: Wet oxidation for process wastewater, flow rate of 18 m³/h at a pressure of 160 bar

LEWA solution:

- LEWA triplex process diaphragm pump with a compact monoblock design
- Hermetically tight diaphragm pump heads made of 1.4404
- Including pipe resonator and drip pan
- Technical design in accordance with API 675 and local guidelines



Industry: Chemicals

Installation location: China

Application: Adding catalysts in high-pressure synthesis, flow rate of 20 m³/h at a pressure of 277 bar

LEWA solution:

- LEWA triplex process diaphragm pump with a compact monoblock design
- Hermetically tight diaphragm pump heads
- Very heavy-duty equipment for a continuous production process

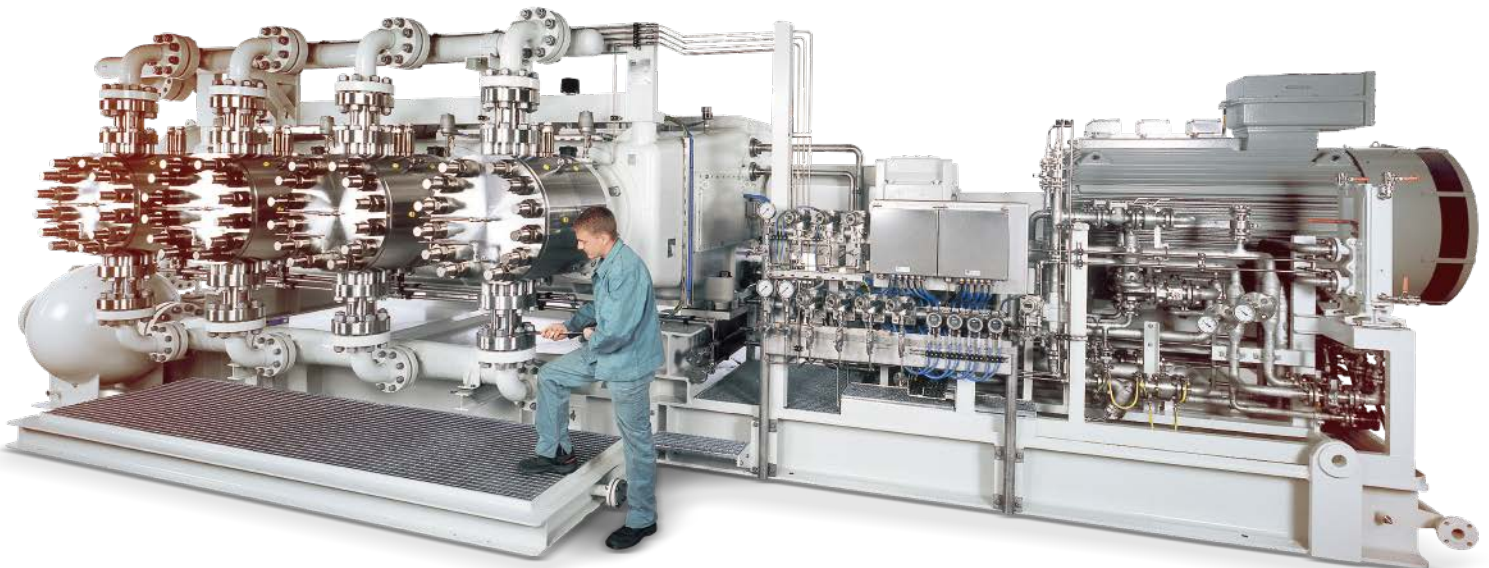

Industry: Oil & Gas

Installation location: Norway

Application: Injection of hydrogen sulfide/ carbon dioxide, flow rate of 100 m³/h at a pressure of 215 bar

LEWA solution:

- Largest process diaphragm pump in the world (62,000 kg)
- Two quadruplex process diaphragm pumps, which can alternate as a stand-by pump
- Ball resonators for pulsation damping
- Hermetically tight pump
- Insensitive to dry running or particles in CO₂
- High efficiency over a wide operating range





Industry: Petrochemicals
Installation location: China



Application: Metering ethylene oxide, flow rate of 5.1 m³/h at a pressure of 107 bar and a temperature of 5°C

LEWA solution:

- LEWA triplex process diaphragm pump with a compact monoblock design
- Hermetically tight diaphragm pump heads
- Valves and pump heads made of special material for an outstanding long service life

Examples of customized process diaphragm pumps.



Industry: Petrochemicals

Installation location: Germany

Application: Metering the melt when filling the high-pressure reactor, flow rate of 2.3 m³/h at a pressure of 250 bar

LEWA solution:

- LEWA triplex process diaphragm pump with a compact monoblock design
- Hermetically tight diaphragm pump heads
- Wetted parts are heated with steam
- Pump synchronization of both process pumps for maximum availability



Industry: Refineries

Installation location: Germany

Application: Conveying washing water with H₂S, flow rate of 8 m³/h with a pressure of 194 bar

LEWA solution:

- LEWA triplex process diaphragm pump with a compact design
- Design in accordance with API 675
- Reliable, hermetically tight pump with long service life, suitable for critical fluids

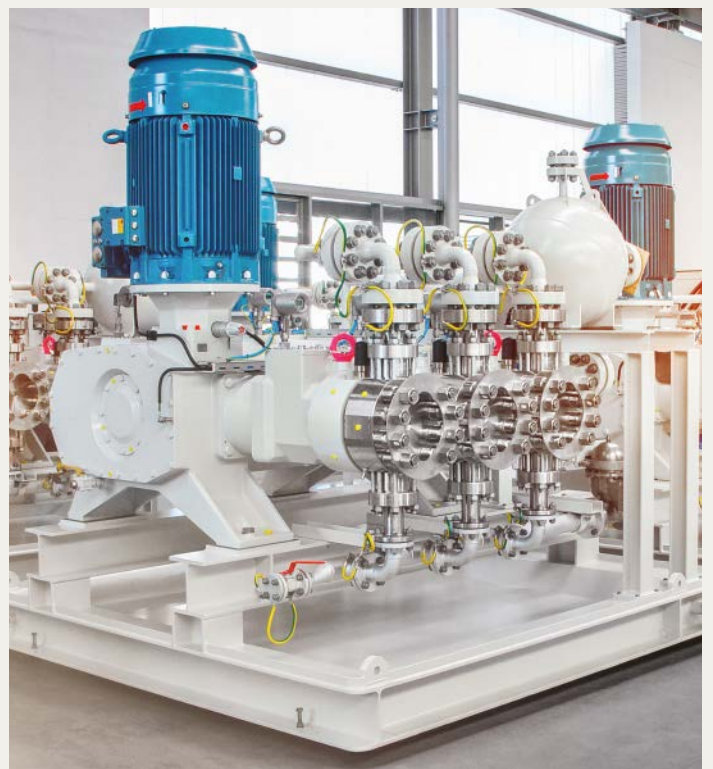



Industry: Petrochemicals

Installation location: Germany

Application: Production of biofuels,
flow rate of 7 m³/h at a pressure of 90 bar and 261°C

LEWA solution:

- LEWA triplex process diaphragm pump with metal diaphragm
- Remote head design for metering extremely hot fluids
- Particularly high hydraulic output with hermetically tight pump
- Very long service life





Industry: Food & Beverages

Installation location: Switzerland

Application: Homogenizing special milk for maximum food safety at a pressure of 500 bar

LEWA solution:

- Complete homogenizer with LEWA triplex diaphragm pump in hygienic design
- With a two-stage homogenization valve (80/500 bar)
- Water-cooled synchronous torque motor
- Hygienic and aseptic design, with FDA approval and in accordance with EHEDG
- CIP and SIP-capable
- Wetted parts in stainless steel, surface roughness $Ra < 0.8 \mu m$, mechanically polished

High performance with minimum footprint: Drive units.

LEWA process diaphragm pumps are available in the compact
LEWA triplex series and in the LEWA ecoflow modular construction.

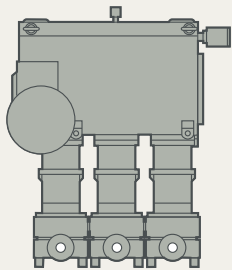

LEWA triplex up to G3R: Monoblock design with integrated gear

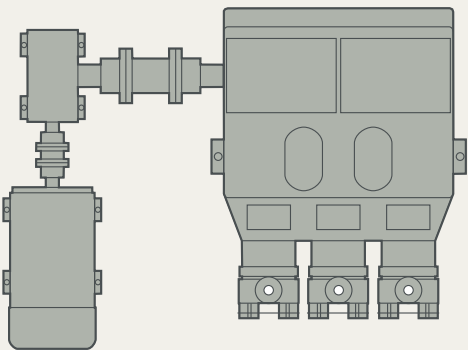

LEWA triplex G3U and G3T with external gear

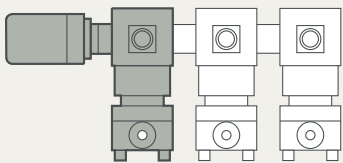

LEWA ecoflow with modular construction

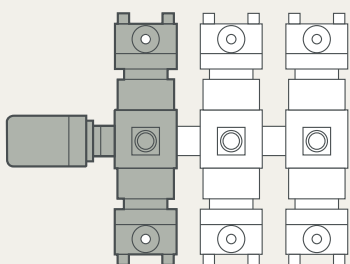

LEWA ecoflow in boxer design

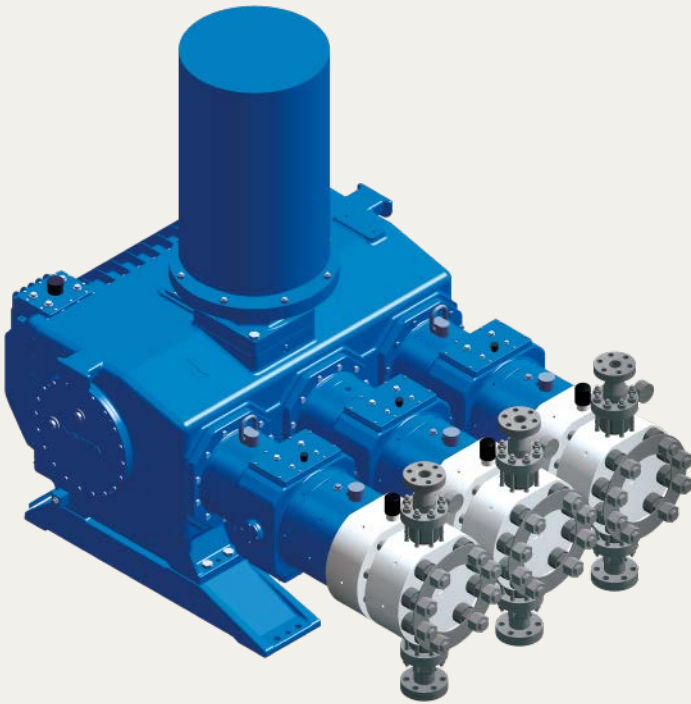

LEWA triplex

LEWA triplex drive units are designed with a compact monoblock design. It offers the following advantages:

- Extremely space-saving and weight-saving
- Solid, rugged overall design
- Very smooth running plus low-vibration operation thanks to even eccentric offset
- Sturdy slide bushings for eccentric shaft and plunger rod drive pin
- Integrated worm gear and vertical flange motor (up to G3R size)
- No base frame required (up to G3R size)
- Low-pulsation design thanks to overlapping partial flows
- Precise, reproducible flow setting using motor speed for adjustment

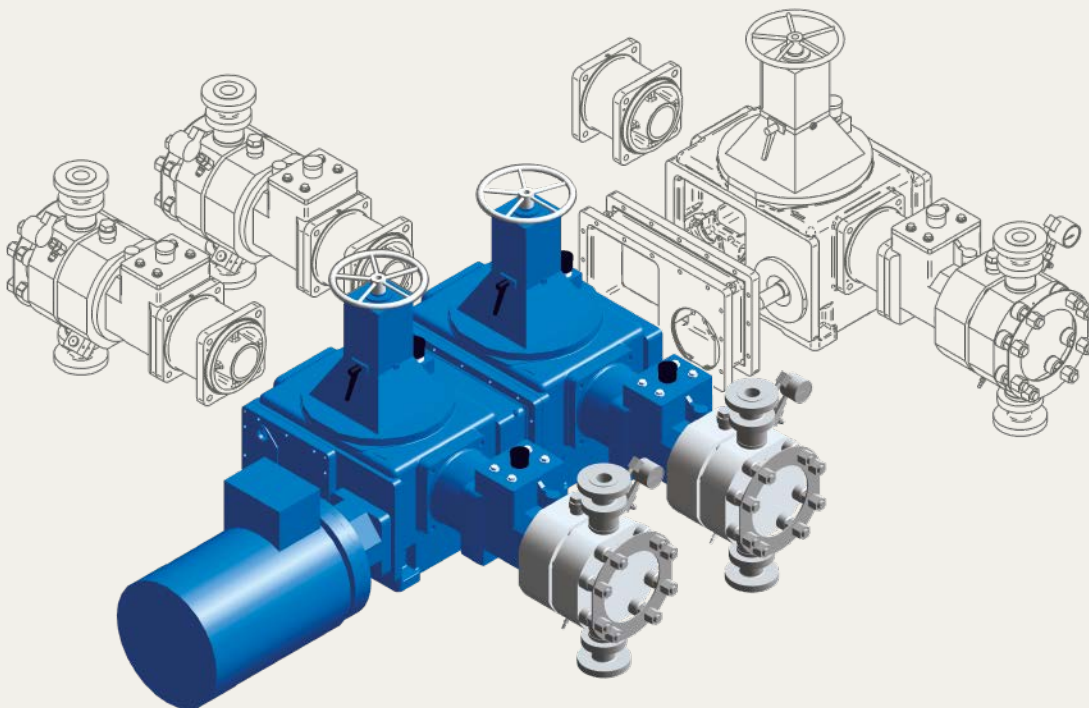

LEWA ecoflow

This highly flexible range, featuring a modular construction, makes it possible to cater to a whole variety of customer requirements. It offers the following advantages:

- Designed specifically for mixture control and highly variable flow rates
- Wide control range up to 1:100
- Precise, reproducible flow setting using stroke length and rotational speed
- For conveying processes combined with metering tasks
- Multiple individual elements, even with different sizes, can be combined
- Duplex, triplex, quadruplex, or sextuplex pumps in boxer design (LDG and LDHB)
- Solid overall design

For compactness and safety. The LEWA triplex technology.

LEWA triplex is a hydraulically actuated process diaphragm pump. The design principle ensures that the diaphragm of the pump head always works in the defined range.

Diaphragm pumps are used when leak tightness, operational reliability and safety are demanded. Especially for fluids that are hazardous, abrasive, environmentally harmful, or sensitive. To keep the load on the diaphragm as low as possible, it is hydraulically actuated in the LEWA triplex.

Minimum dead space

Pump head design with high-performance diaphragm optimized to minimize dead space

Pressure relief valve

A pressure relief valve in the hydraulic part of the pump prevents any overload occurring in the pump. It is individually adjustable. (Type-tested version also available).

The right material for every application

Materials are selected in collaboration with the customer and with the fluid properties taken into account

Low-wear valves for a variety of tasks

Operational reliability and service life are decisively dependent on valve quality. The valve design is therefore adapted to the specific application.

Highly precise hydraulic control

The hydraulic valve ensures stable, precise operating condition

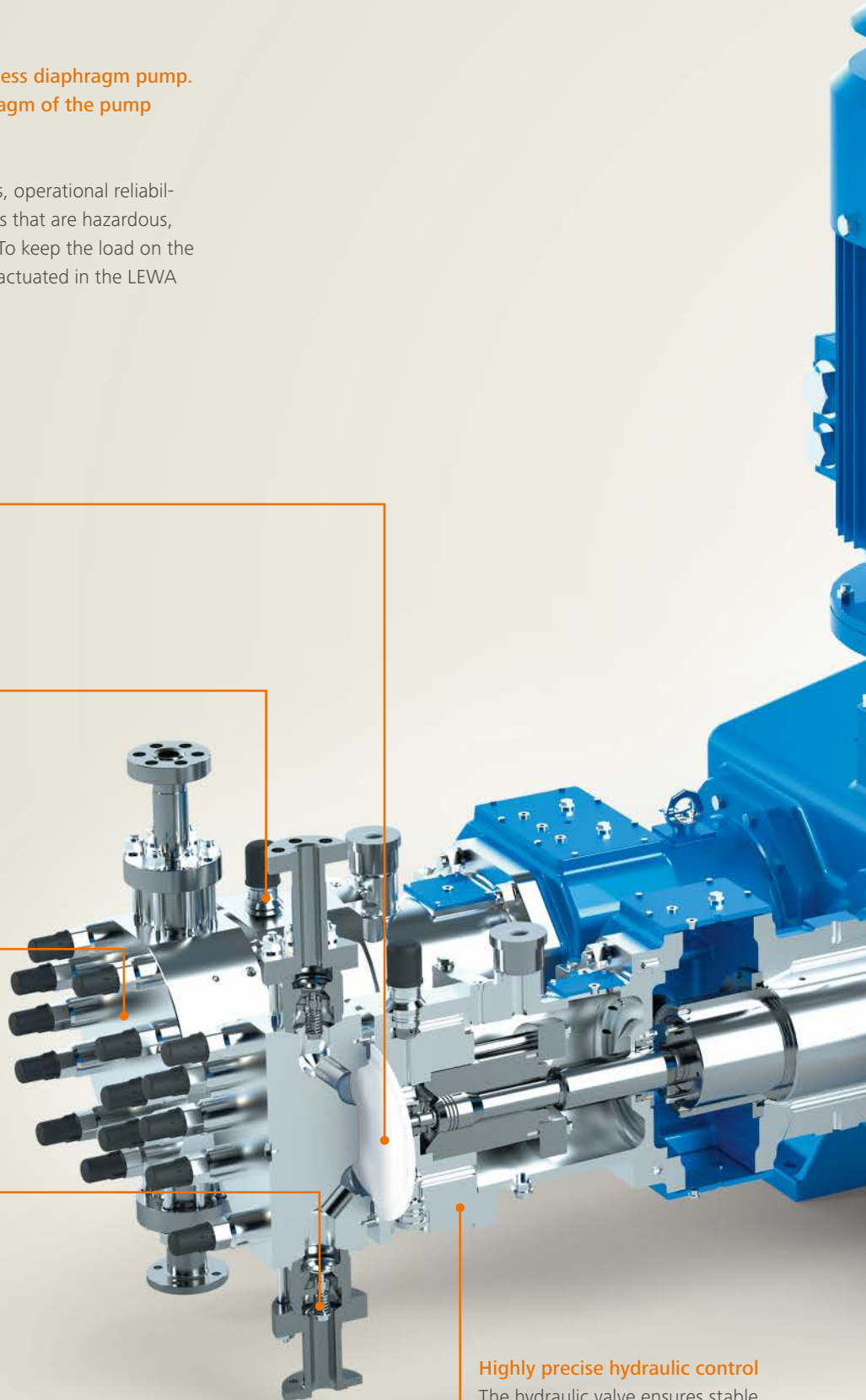

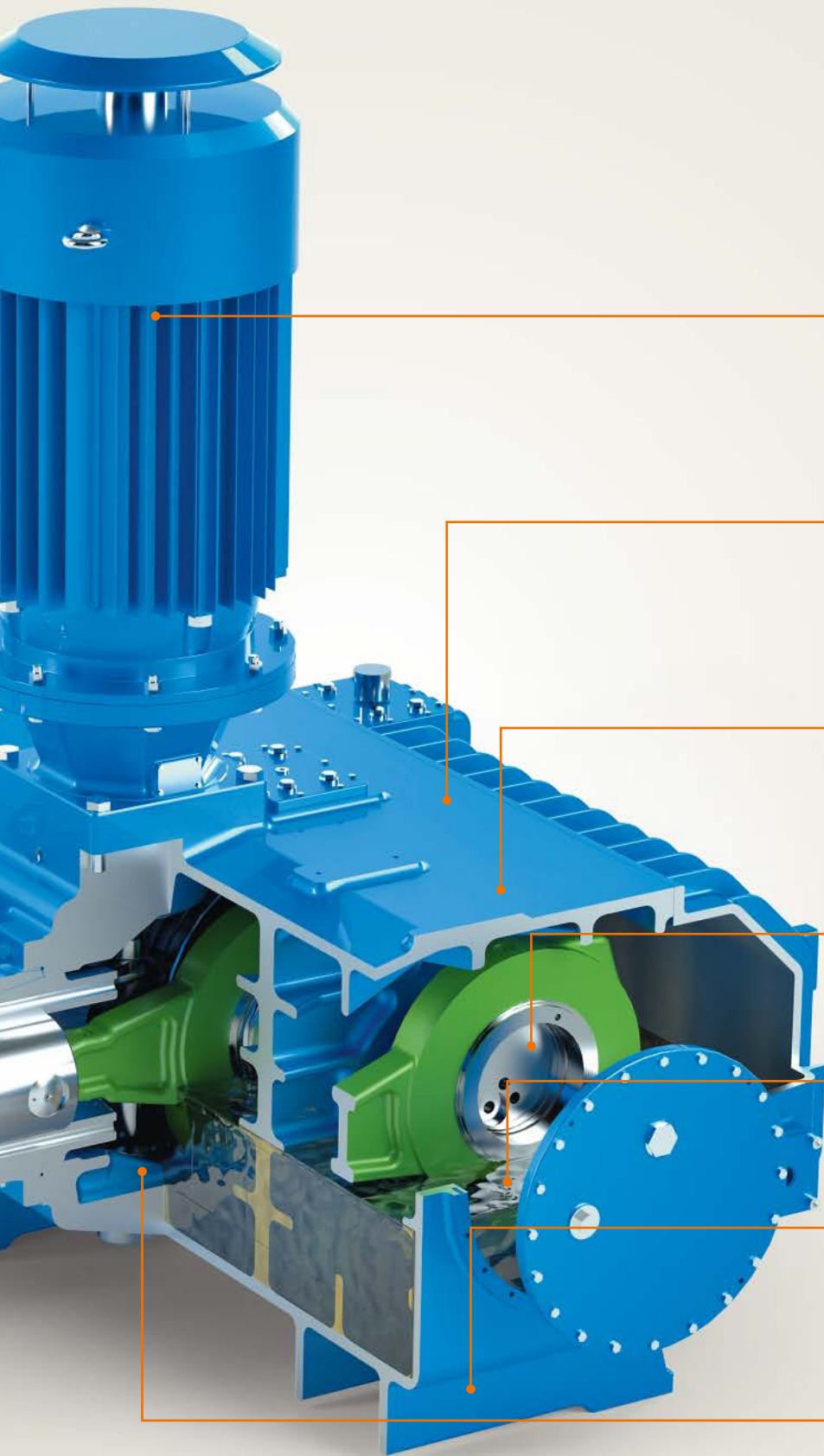

High-performance drives for continuous operation

Frequency-controlled 3-phase motors for low and medium voltage. Special solutions available.

Overall design for low-vibration operation

This avoids the use of shock absorber

Monitoring

the temperature of the drive unit oil

Solid crank shaft

for maximum hydraulic output

Lubrication

All moving parts run with immersion splash lubrication

Low space requirement

Compact foundation dimensions thanks to vertical motor installation

Multi-chamber system

for separating hydraulic and drive unit oil

For a wide variety of requirements.
The LEWA pump heads.



Series

M900

The universal choice for fluids of any kind

Innovative diaphragm pump head is the latest generation for maximum operational reliability. The patented LEWA DPS technology also enables a suction capacity that is globally unique in the field of hydraulically actuated diaphragm pumps.



Series

M800

The compact choice for highest pressures

The special geometry of the diaphragm clamping system enables the use of PTFE diaphragms for pressure ranges up to 1,000 bar resulting in a very compact design.



Series

M500

The proven choice for high flow rates

Universal diaphragm pump head for high flows. Proven, durable, reliable, and with patented diaphragm position control.

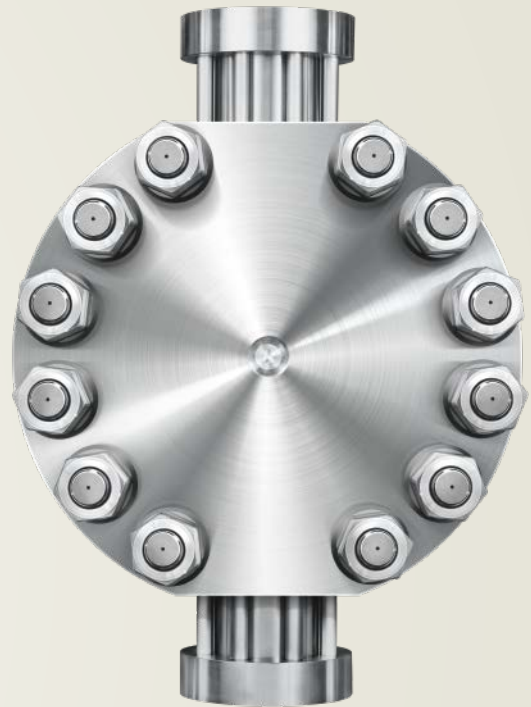

Series

M400

The extreme choice for high temperatures

M400 pump heads have a metal diaphragm and are designed for high temperatures and pressures up to 1,200 bar. Also suitable when a high degree of permeation resistance is required.

For fluids of any kind.

Universal M900 diaphragm pump heads.

The innovative M900 pump head is the latest generation of pump head, with PTFE sandwich diaphragm for maximum operational reliability.

As a further development to the M500 series, it is just as durable and proven, however has more safety reserves, especially when starting the pump. The patented DPS technology also enables a suction lift capability that is globally unique in the field of hydraulically actuated diaphragm pumps.

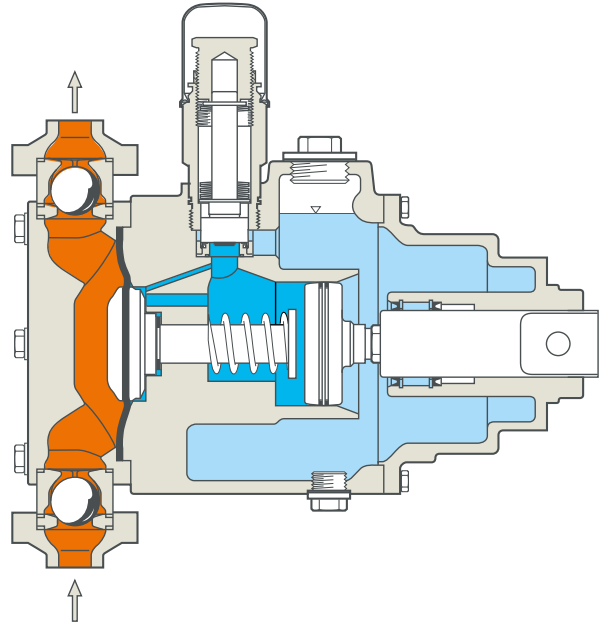

Technical data

Discharge pressure up to 500 bar

Flow rate up to 6 m³/h per pump head

Temperatures of -20 to +150°C

Viscosity up to 100,000 mPa·s

316/316L, special materials

Can be installed on all ecoflow drive units
and all triplex drive units ≤ G3G

Outstanding advantages

Globally unique suction lift capability

Suitable for vacuum extraction

Simple, reliable start-up,
even under extreme conditions

Patented DPS diaphragm protection system

Very low maintenance costs and long
service intervals

Insensitive to particles in the fluid

Dry run safe

Integrated pressure relief valve

For highest pressures. Compact M800 diaphragm pump heads.

The M800 pump head is a diaphragm pump head with PTFE sandwich diaphragm.

The special geometry of the diaphragm clamping system enables the use of PTFE diaphragms for pressure ranges up to 1,000 bar and resulting in a compact design. Very economical solution in the range of high pressures, especially in comparison to pump heads with metal diaphragms.

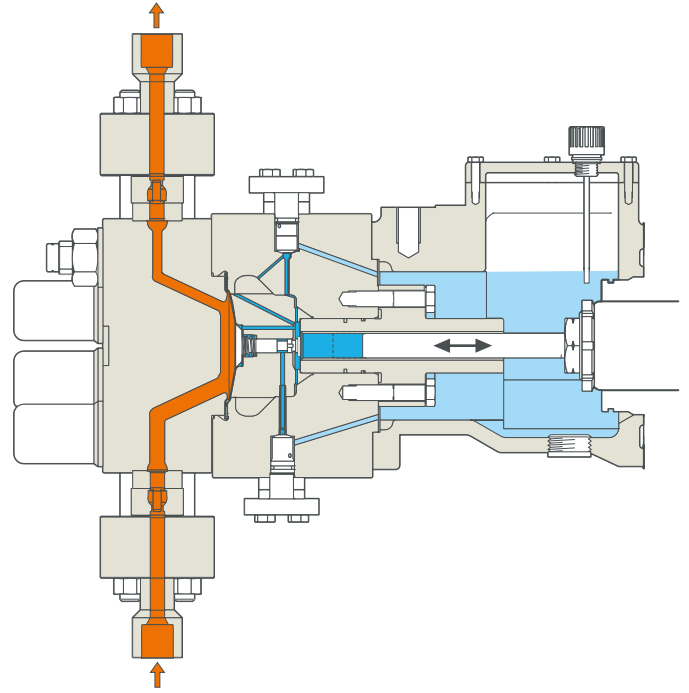

Technical data

Discharge pressure up to 1,000 bar

Flow rate up to 1.1 m³/h per pump head

Temperatures of -10 to +60°C

Viscosity up to 100,000 mPa·s

1.4313 or 1.4462 (Duplex)

Can be installed on all ecoflow drive units ≥ LDF and all triplex drive units

Outstanding advantages

Extremely high operating pressures possible

Compact design and smallest possible use of materials by using PTFE diaphragms even in the high-pressure range (and so having smaller outer diameters in comparison with metal diaphragm pump heads)

Insensitive to particles in the fluid

Dry run safe

Integrated pressure relief valve

For high flow rates. Proven M500 diaphragm pump heads.

The M500 diaphragm pump head with PTFE sandwich diaphragm is universally applicable. It is perfect for high flow rates.

The M500 has been in successful use for decades. Its advantages are robustness, reliability, and its patented diaphragm position control.

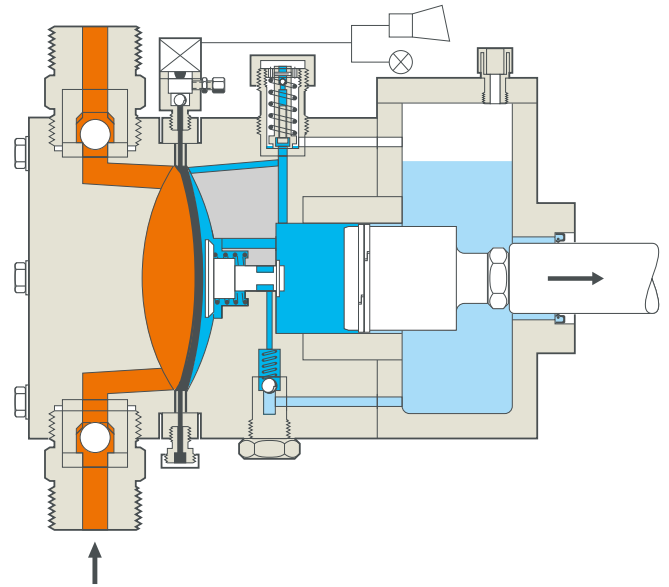

Technical data

Discharge pressure up to 350 bar

Flow rate up to 19 m³/h per pump head

Temperatures of -50 to +150°C

Viscosity up to 100,000 mPa·s

316/316L, plastics PVC or PVDF, special materials

Can be installed on all ecoflow drive units ≥ LDE and all triplex drive units

Outstanding advantages

High suction capacity due to diaphragm position control

Very low maintenance costs and long service intervals

Suitable for high flow rates

Insensitive to particles in the fluid

Dry run safe

Integrated pressure relief valve

For high temperatures. M400 diaphragm pump heads for extreme requirements.

The M400 pump head with metal diaphragm is selected for highest pressures and temperatures. It is also suitable when a high degree of permeation resistance is required.

The diaphragm is working between two contour plates, limiting the deflection of the diaphragm and providing an extreme level of operational reliability. The diaphragm monitoring system offers a plus for safety by immediately displaying the damage of a diaphragm layer.

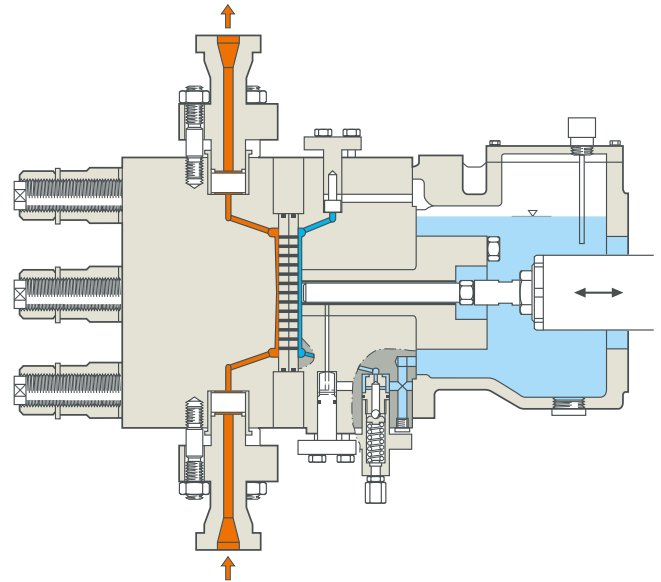

Technical data

Discharge pressure up to 1,200 bar

Flow rate up to 0.8 m³/h per pump head

Temperatures of -40 to +200°C

Viscosity up to 500 mPa·s

1.4313, 316/316L, special materials

The M400 can be installed on all ecoflow drive units
≥ LDF and all triplex drive units ≤ G3G

Outstanding advantages

Extremely high operating pressures possible

Extremely high operating temperatures possible

Diffusion-tight metal diaphragm

Dry run safe

Integrated pressure relief valve

For the optimum configuration. Overview options.

Instrumentation, control, and monitoring

Integration of the pump into the process control systems for control, regulation, and condition monitoring

Diagnostic connection for the online readout of measurement data from the pump head and drive

Diaphragm monitoring systems to spec with pressure switches, manometers, contact manometers, and pressure transmitters

Pump synchronization

Converter and control cabinets

On-site control panel

Pump head designs

Special materials by customer request, such as Hastelloy, duplex, titanium, plastics

Diverse connection geometries

CIP and SIP capability

Hygienic design

Heating and cooling jacket

Fully heated pump heads (including valves) for melting

Remote head design for extreme temperatures

Accessories

Pulsation damper

Safety valve

Pressure retention valve

Flow meter

Base plate

Collecting pipe



Industry: Energy utilities

Installation location: Germany

Application: Compressing liquefied gases with diaphragm pump skid, flow rate of 2.4 m³/h at a pressure of 62 bar

LEWA solution:

- Engineering, assembly, and commissioning from a single source
- Process diaphragm pump complies with stringent safety requirements
- Designed for low inlet pressure levels
- Enables compression in a single stage
- High energy efficiency



At a glance.

Technical data.

Performance overview of LEWA ecoflow and LEWA triplex process diaphragm pumps

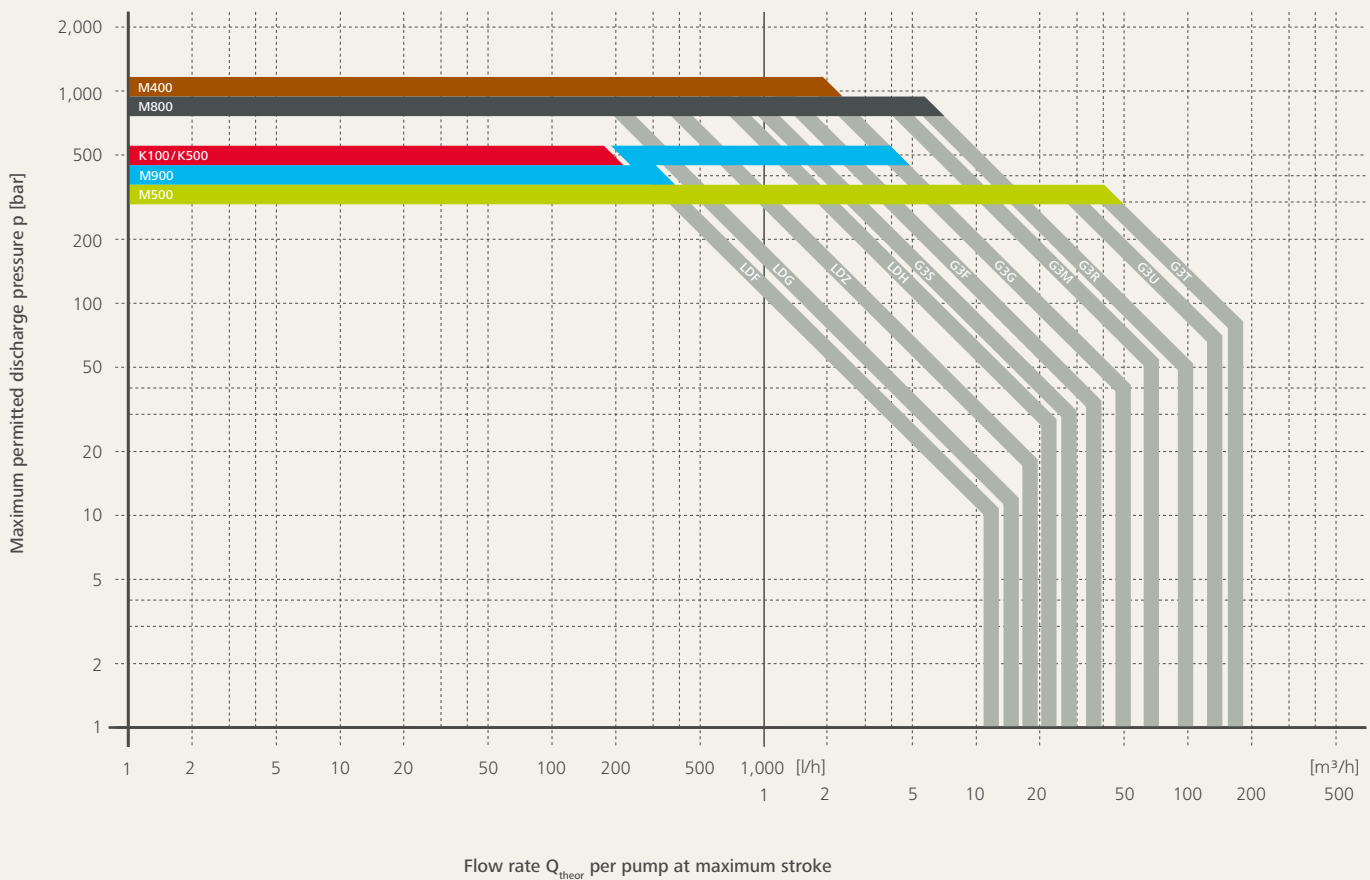

Performance overview to determine drive unit size.
The characteristics apply to a single pump.

Technical data for pump heads

	Pump head M900	Pump head M800	Pump head M500	Pump head M400
Max. discharge pressure [in bar]	500	1,000	350	1,200
Max. flow rate [in m ³ /h]	6	1.1	19	0.8
Temperatures [in °C]	-20/+150	-10/+60	-50/+150	-40/+200
Max. viscosity [in mPa·s]	100,000	100,000	100,000	500
Applicable	on all ecoflow drive units and all triplex drive units ≤ G3G	on all ecoflow drive units ≥ LDF and all triplex drive units	on all ecoflow drive units ≥ LDE and all triplex drive units	on all ecoflow drive units ≥ LDF and all triplex drive units ≤ G3G

Assembly dimensions

in mm	Type G3S	Type G3F	Type G3G	Type G3M	Type G3R
L	1,300	1,550	2,200	2,300	2,950
W	1,150	1,300	1,750	1,900	2,050
H	1,350	1,850	1,950	3,150	3,900

The dimensional specifications differ depending on the pump head installed.

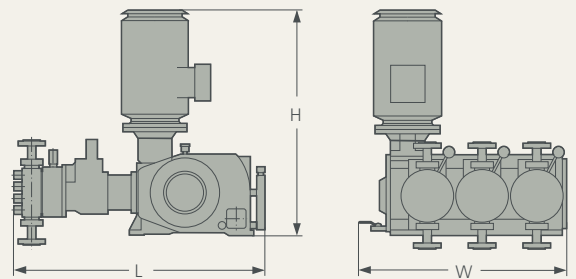

in mm	Type G3U	Type G3T
L	3,300	3,600
W	4,450	4,950
H	1,350	2,200

The dimensional specifications differ depending on the pump head installed.

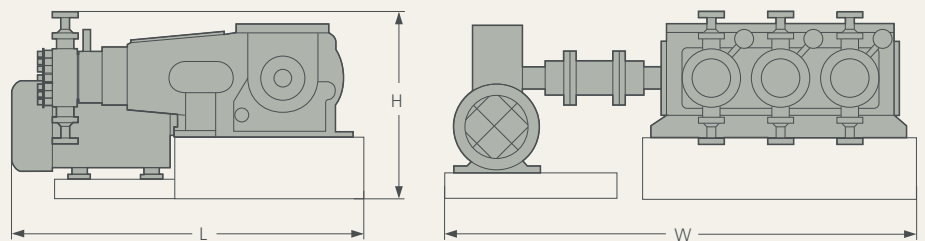

in mm	Type LDF	Type LDG	Type LDZ	Type LDH
L	1,130	1,300	1,700	2,100
W	900	1,300	1,700	1,800
ΔW	430	490	700	717
H	940	1,000	1,140	1,500

The dimensional specifications differ depending on the pump head installed.

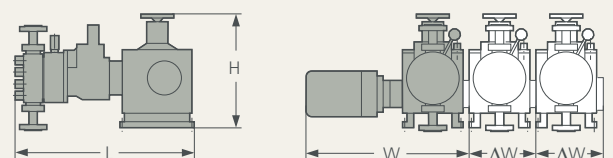

Complete solutions from a single source. LEWA packages and systems.

LEWA also offers solutions that go beyond individual process or metering pumps. For decades, we have built customer-specific systems, skids, and packages. Our services range from engineering to commissioning – including custom system controllers, process visualization, operational data collection, and external interfaces to the process control system.

We guarantee the optimum implementation of your requirements with our knowledge of intelligent process control and the controller and regulation technology needed to achieve it.

The basis is the competent selection and combination of system components and their characteristics. As our basic component, we prefer to use LEWA ecoflow metering diaphragm pumps.



Each process has specific requirements. LEWA's experts tailor all components carefully to each other and bring in valuable industry know-how.

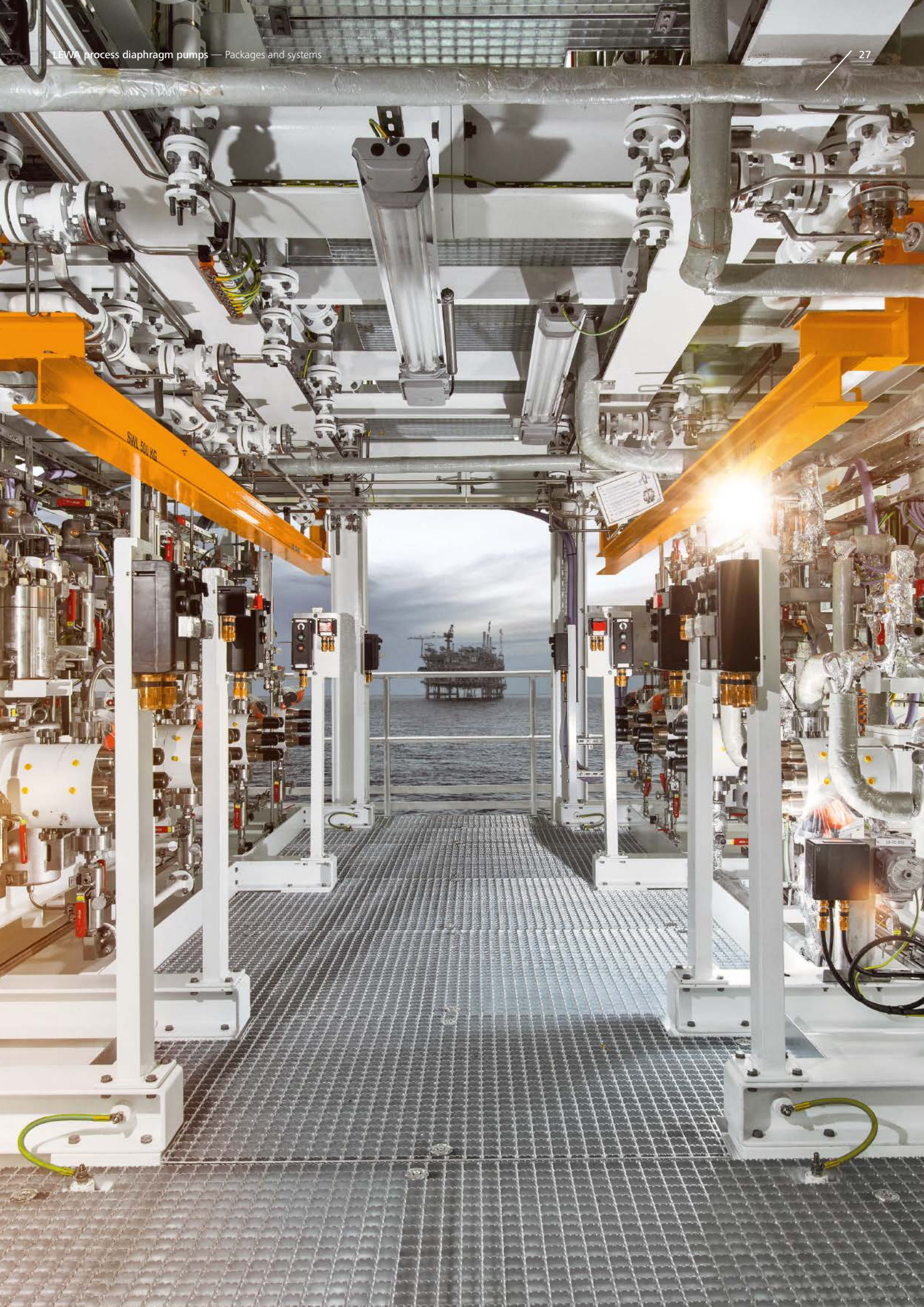

Creating Fluid Solutions. For more value created.



Technical consulting

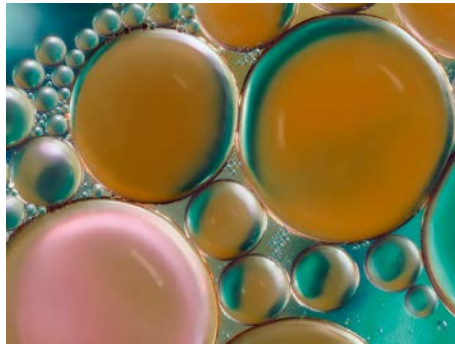

Fluid and process engineering tests



Lifecycle concepts and energy optimization

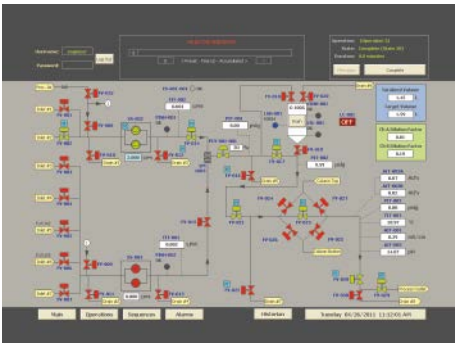

Process automation

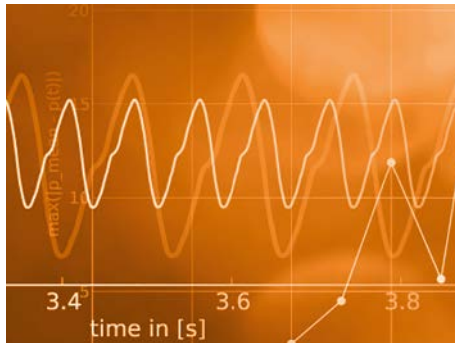

Pulsation studies and pipeline calculations



System layout and integration



Creative development and refinements

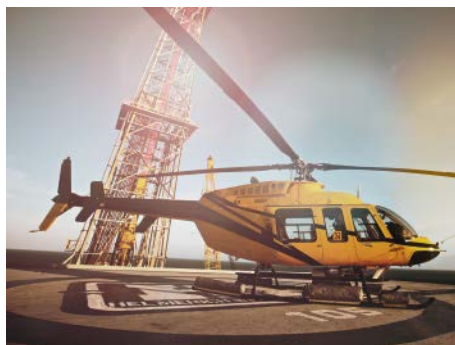

Commissioning and maintenance service



Spare part and service concepts

Creating Fluid Solutions.

Driven by our commitment, our trendsetting products and innovative technologies have set benchmarks for diaphragm pumps and metering systems for over 70 years. We solve complex tasks from a single source. That ranges from custom pump design, basic and system engineering, global project management, and pretesting to commissioning and maintenance on site. Our consistent drive always to develop the best solutions for the customer provides you with a competitive advantage and visible added value.

Your local representative:



LEWA GmbH
Ulmer Str. 10
71229 Leonberg
Germany

www.lewa.com